



BN Products-USA™

A DIVISION OF BENNER-NAWMAN, INC.

DBR-25WM

Rebar Bender

Customer Service (800) 992-3833

**ELECTRIC / HYDRAULIC REBAR
BENDER & STRAIGHTENER**

OPERATOR MANUAL
DBR-25WM

115V AC

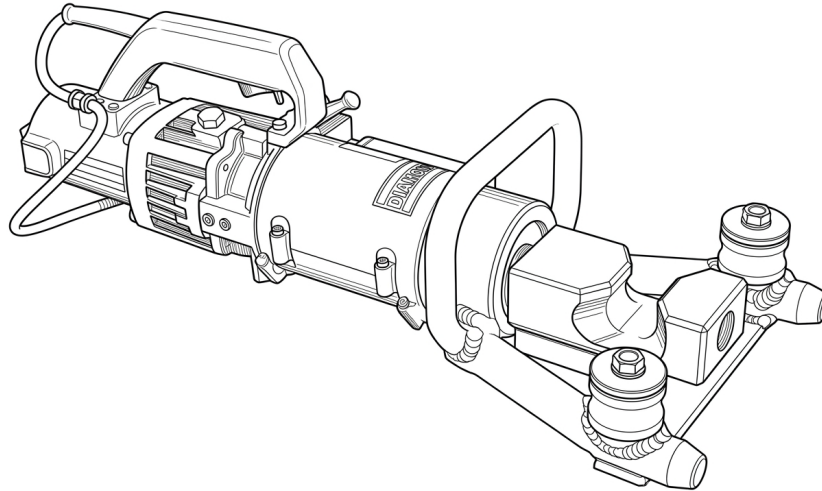

**REBAR STRAIGHTENER
HANDLING INSTRUCTIONS**

**READ THESE INSTRUCTIONS CAREFULLY BEFORE
ATTEMPTING TO USE REBAR STRAIGHTENER**

Not following proper operating procedures can lead to accidents.
If in doubt of any procedure, contact your local authorized agent.

The DBR-25WM is a portable heavy-duty electric/hydraulic rebar bender and straightener. It helps save valuable man-hours by cleanly and efficiently bending or straightening bent rebar. It functions as a simple 90-degree portable electric rebar bender. The interchangeable bending hook covers rebar diameters from #4 to #8 grade 60. Maximum pressure for bending and straightening ranges from 8.5 to 11 tons. It's portable and versatile enough to bend or straighten rebar in-place with its push/pull hydraulic capabilities. It will bend a 90-degree angle in only (4) seconds. The bending head also rotates 360 degrees. Ships complete in a plastic carrying case with hydraulic oil, a tool kit and two additional bending dies. This tool solves unique bending applications that other tools cannot.

BN Products-USA™

3450 N. Sabin Brown Road • Wickenburg, AZ 85390

(800) 992-3833 • mail@bnproducts.com

Website: www.BNProducts.com



GENERAL SAFETY PRECAUTIONS

Application: Use DBR-25WM on concrete re-enforcing bars only.

RESTRICT USE TO DESIGNATE MATERIALS

There is always a chance that the end of material may break and shoot out, especially if the material is harder than those specified. Exceeding designated material specifications greatly increase this risk and will also damage the tool. Do not attempt to use the tool for rebar harder, thicker, or thinner than those specified.

USE EYE PROTECTION

Wear safety goggles, safety glasses with side shields or a face shield when using the rebar straightener.

KEEP HANDS AWAY

Do not touch rebar, housing, hook, rollers, and/or the piston while rebar straightener is being operated.

GUARD AGAINST ELECTRIC SHOCK

To avoid possible electric shock, do not handle the DBR-25WM with wet hands, or use in the rain or other damp places. Be aware of all power lines, electric circuit and other hazards that may be contacted, especially those that are below the surface or otherwise hidden from view.

UNPLUG TOOL

Disconnect the tool from outlet when not in use and before cleaning, adjusting, or servicing. Do not disconnect plug from outlet by pulling on the cord. Always check that the switch lock is OFF before plugging your tool in.

BEWARE OF YOUR ENVIRONMENT

Do not use rebar straightener in the presence of flammable materials (e.g., paint, thinner, petroleum products, and adhesives.) Do not use rebar straightener in a possibly explosive environment, (e.g., fumes, gas, or dust) or in areas that are poorly ventilated.

KEEP WORK AREA TIDY AND WELL LIT

Make sure that work area is properly lighted and clear of obstructions. Operator should at all times have an unobstructed view of their rebar straightener, rebar, and the surrounding area.

WEAR PROPER APPAREL

Do not wear loose clothes, dangling objects, or jewelry. Restrain long hair. The use of a safety helmet and rubber soled boots are strongly recommended. If safety gloves are worn, be especially careful that gloves do not get caught in the moving parts.

KEEP VISITORS AWAY

Keep all visitors at a safe distance from the work area for their own protection and to prevent distraction of the operator.

Max Rebar Diameter	25 mm			
Straightening	Max yield point 345N/mm2			
Bending	Max yield point 295N/mm2			
Rebar Diameter	Straightening Capacity		Bending Capacity	
	Push	Pull	Push	Pull
13 mm	up to 125°	up to 121°	up to 94°	up to 92°
16 mm	128	124	90	90
20 mm	130	126	90	90
25 mm	132	124	90	90
Max pressure	11 Tons	8.5 tons	11 tons	8.5 tons
Output	1.5 HP			
Weight	22.5 Kg			
Dimension	660x270x200mm (LxWxH)			



MAINTAIN REBAR STRAIGHTENER WITH CARE

Inspect rebar straightener before each use. Faulty or loose bending hook could possibly result in personal injury. Keep handle dry, clean and free from oil and/or grease. Keep housing and piston free of dirt and iron filings. Check that no screws or bolts are loose or missing. Follow all instructions for maintenance. Inspect switch, cord, plug and any extension cable at regular intervals.

STORE CAREFULLY

When not in use, store rebar straightener and its accessories in a dry place where they cannot be accessed by anyone but the operators.

PARTS AND SPECIFICATIONS (Figure 1)

1. Handle
2. Switch
3. Mode control lever
4. Oil plug
5. Front handle
6. Hook
7. Roller
8. Housing
9. Motor

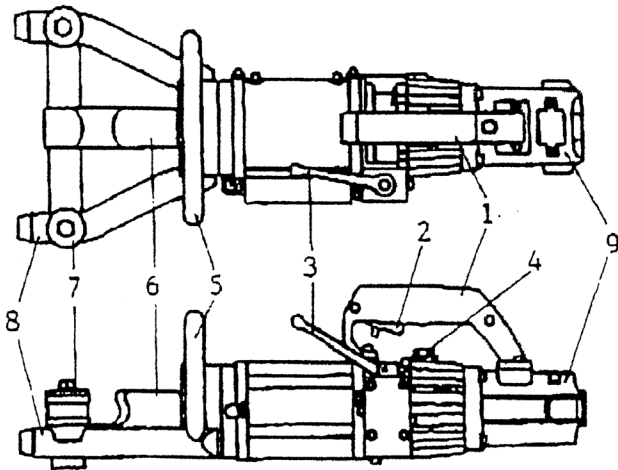

OPERATING INSTRUCTIONS

Check the oil level.

Check that the power source is appropriate to the rebar straightener.

CARE- If voltage is too high, the motor will burn out, if voltage is too low, insufficient power will be generated.

NEVER USE DC CURRENT OR AC HIGHER THAN 110V
Check that the power supply is properly earthed.

CAUTION- Failure to properly earth the power supply may result in a shock to the operator.

Check that the cord is undamaged and that the plug is not loose.

CAUTION- Cut or abraded covering could result in a short and electric shock to the operator.

If an extension cord is to be used, make sure that it is undamaged and that it is the proper thickness for the length. See table below.

	100/115V	230V
Cable Length	Cable Size (AWG)	Nominal Diameter
Up to 10m (33 ft.)	16	1.0mm ²
Up to 15m (50 st.)	14	1.25mm ²
Up to 30m (100ft.)	10	1.5mm ²

Before plugging the tool in, make sure that the switch lock is off.

CAUTION- If switch lock is ON; the rebar straightener will start as soon as it is plugged in. To disengage lock, pull the trigger switch, the lock button will pop out.

WARM UP

In cold weather, warm up the unit for 30-60 seconds so that the hydraulic oil will reach the proper viscosity. Pull the trigger switch to extend the piston and release when it has reached its full stroke. Repeat this action 3-5 times.

POINTS OF ATTENTION

1. Do not cover air vents.
2. CARE- If vents are covered, the motor will overheat and may burn out.
3. If hydraulic oil exceeds 70°C, (158°F) the power will drop. Allow the unit to cool before resuming operation. (Be particularly careful in summer, when the aluminum pump heats up more quickly).

- If a drop in power is observed and motor is unusually hot, check the carbon brushes.

OPERATION

The DBR-25WM is primarily intended to straighten deformed rebar. It can, of course, also be used to bend straight rebar.

To enable the unit to be used in confined spaces, there are two operating modes: Push & Pull. The mode is selected by moving the mode control lever to the appropriate position.

“A” for push (piston advances) and “B” for pull (piston retracts) In either mode, simply press the switch to move the piston.

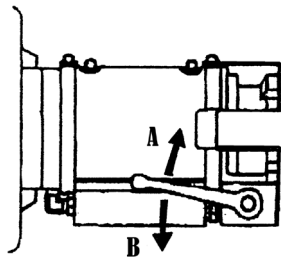

NB: The movement of the piston is limited by a safety valve. To prevent overheating, release the trigger switch when the piston has reached its travel limit.

TO PUSH

Advance or retract the piston so that the hook is in a suitable starting position. Set the mode control lever to “A” and fit the rebar as shown at the left. Pull the trigger switch until the rebar is at the desired angle.

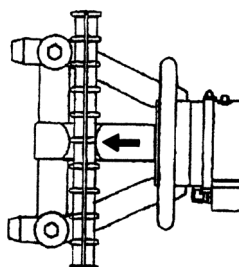

TO PULL

Set the hook in the correct starting position, make sure that the mode control lever is in the “B” position and fit the rebar as illustrated. Pull the trigger switch until the

desired angle is attained.

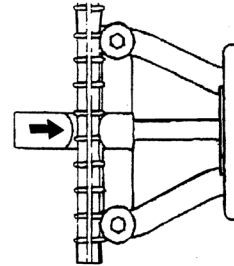

NB: It is important that the rebar be properly fitted in the hook and against the rollers.

INTERIOR ANGLE

Since the piston stroke is limited, interior straightening / bending angle will vary according to rebar diameter and operating mode. Refer to the table below.

CLEANING

Clean rebar straightener everyday, preferably immediately after use.

CAUTION- Wear gloves to protect hands from metal splinters. Do not use air guns – Blasting with air guns can cause metal filings and/or dust to get into eyes and respiratory system.

1. Disconnect unit.
2. Wipe or brush away all dirt and metal filings. Pay particular attention to the lower half of the piston, where dirt is more easily accumulated.
3. Once the piston has been retracted, pull the trigger switch long enough to partially unplug unit. Check the piston for accumulated dirt and iron filings that may be jamming the piston.

OIL LEVEL CHECK

As rebar straightener is hydraulically operated, the oil level must be checked at frequent intervals, preferably everyday. Failure to maintain the oil at proper levels will result in a drop in pressure and loss of the benders hydraulic power.

CAUTION- Hydraulic oil is highly flammable. Keep away from sparks and naked flame. **DO NOT SMOKE WHEN NEAR OIL/BENDER.**



CAUTION- Hydraulic oil may cause inflammation of the eyes and skin. If ingested, it will cause diarrhea and vomiting.

In case of eye contact, rinse in clean water for at least 15 minutes and consult a physician immediately, as blindness can occur.

In case of skin contact, wash thoroughly with soap and water.

In case of ingestion, consult a physician immediately. DO NOT DELIBERATELY INDUCE VOMITING.

OIL MAINTENANCE CON'T.

1. Oil should be warm, but not hot. Warm up the unit if cold.
2. Unplug unit from the power source.
3. Remove oil plug and the seal washer (packing)
4. CAUTION- Never remove oil plug when unit is hot, as the oil may spurt over.
5. Check that oil is level with the bottom of the plug hole (i.e. the pump case is full to the brim) If oil level is too low, top up with 20- weight hydraulic oil with anti-foam and anti- abrasion properties (ISO viscosity grade VG46, e.g., Shell Tellus 46, Mobil Oil DTE-25, or Esso Uni Power SQ46)
6. After topping up, extract air from the system. Gently tilt the unit and return it to the level position. Top up again and tilt in the opposite direction. Repeat this action until all air has been removed.
7. CARE- Rebar straightener cannot function properly if oil contains air bubbles.
8. Replace seal washer and plug. Extend to its full stroke, and remove oil plug and seal washer. Then repeat the procedure of above
9. Replace the oil plug and seal washer.

OIL CHANGE

The hydraulic oil should be changed at least once a year, sooner if it appears to be dirty.

1. Unplug the unit from the power source. Remove the oil plug and packing. Turn the unit over and drain oil into an appropriate receptacle.
2. With drain hole uppermost, slowly fill the unit with fresh oil. Replace plug and lightly tighten. Connect the unit to power source and advance piston two or three times. Unplug the unit and remove the oil plug. Top up the oil level and replace plug.

3. Finally, follow procedure for oil level check.

Please dispose of any hydraulic oil in accordance with local regulations. Do not pour into sea, a river, lake or drains.

BOLT TIGHTNESS

Once a week, or after every 30 times use, check the tightness of all bolts, especially those securing the housing to the cylinder.

CARBON BRUSHES

Inspect the two carbon brushes at least every two months. (Normal brush life is around 200 hours. CARE- Worn carbon brushes will result in power loss, cause the motor to run hot and irreparably damaging the armature's commutator.

1. Disconnect unit.
2. Unscrew both brush caps and pull out the carbon brushes.
3. Replace the brushes if less than 6MM in length.

OVERHAUL

Return the unit to an authorized agent for overhaul at least once every two years, sooner if subject to heavy usage.

Maximum Bending Diameter	1" #8 Rebar (25mm) Grade 60
Bending Angle	Up to 94 degrees (1/2") - up to 90 degrees (1")
Voltage/ Amperage	115V 50/60Hz / 12 amps
Tool Weight	57.3 lbs (26 kg)

BN Products-USA™

3450 Sabin Brown Road • Wickenburg, AZ 85390

(800) 992-3833 • (928) 684-2813

Fax: (928) 684-7041 • mail@bnproducts.com

www.BNProducts.com



DBR-25WM Dies and Hook Bending Radiuses Standard with DBR-25WM Bender/Straightener

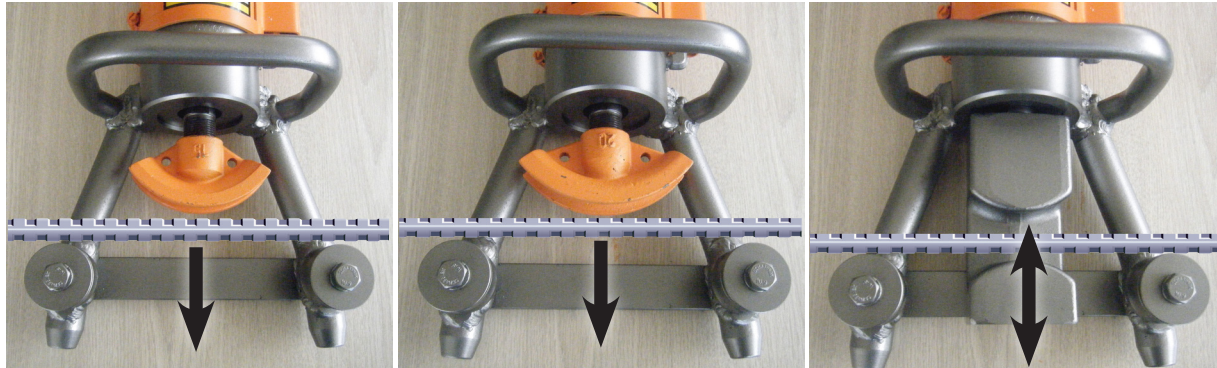

BD25WH Bending Die Set		
#15 Bend Die	#20 Bend Die	1DBR80A Bend Hook (Standard)
M16 x D7 Female Threads on one end	M16 x D7 Female Threads on one end	M16 x D7 Female Threads on both ends
Marked: 1/2" & 15	Marked with: 3/4" & 20	3 inches wide
With this bending die push/bend forward only	With this bending die push/bend forward only	With this bending hook push/bend forward & pull/bend backwards or straighten rebar
4.5" Bend Radius	6" Bend Radius	3.75" Bend Radius

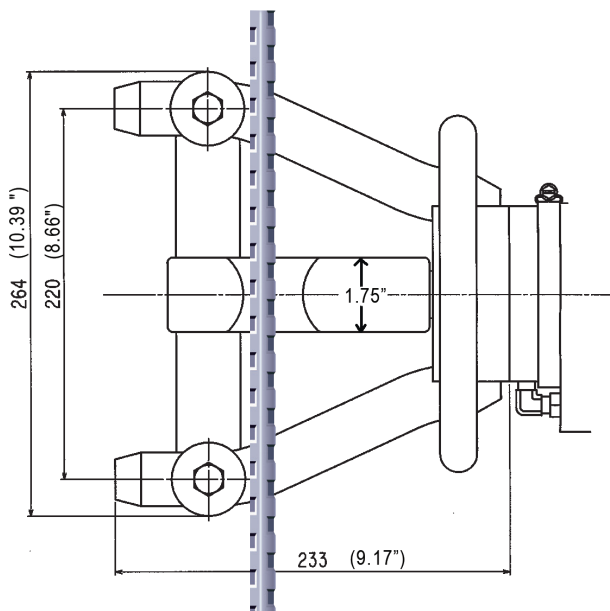

Special order 1DBR80 bend die available upon request. It measure 1 3/4" wide

Notes: For In-place bending applications the bending head pictured to the left needs to be raised at least 1.5" off the surface of the concrete in order to make a complete 90 degree bend. The minimum height above the concrete surface in which a bend can be made is 6" or 152.5 mm.

MAINTENANCE PARTS

DBR-25WM

Accessory, maintenance parts and and replaceable components are available though BN Products-USA™ Distributors.

If assistance is required, please contact BN Products-USA™ Customer Service at (800) 992-3833.

PRODUCT NUMBER	DESCRIPTION
BN7356	Hydraulic Oil (1 Quart)
BD25WK	Bending Die Set (1/2" & 3/4" bending dies)
1DBR80A	Large Radius Bending Hook

DBR-25WM

Electric / Hydraulic Rebar Bender and Straightener

Parts Guide, Brochure, and additional resources may be found online at:

BNProducts.com

<https://www.bnproducts.com/tools/dbr-25wm-portable-rebar-bender/>



BN Products-USA™

A DIVISION OF BENNER-NAWMAN, INC.

DBR-25WM

Rebar Bender

Customer Service (800) 992-3833

ONE-YEAR LIMITED MANUFACTURER WARRANTY

BN Products-USA™ warrants each tool to the original purchaser to be free of defects in materials and workmanship under everyday and appropriate use and service for one year. Use the applicable QR code or web URL below to access our full One-Year Warranty policy and procedure, or to complete a Warranty Service Request for this product.

If you are requesting Warranty Service, it is recommended that you have your original purchase order available to upload or scan using a mobile device. Questions with regard to our One-Year Limited Manufacturer Warranty may be directed to BN Products-USA™ Customer Service at (800) 992-3833.

SCAN 	ONE-YEAR LIMITED WARRANTY https://www.bnproducts.com/one-year-product-warranty/ 		REQUEST WARRANTY SERVICE ONLINE https://www.bnproducts.com/warranty-request/ 
--	---	--	--



BN Products-USA™

3450 N. Sabin Brown Road | Wickenburg, AZ 85390

(800) 992-3833 | www.BNProducts.com

THE MOST TRUSTED NAME IN REBAR TOOLS